

AUTOZON™

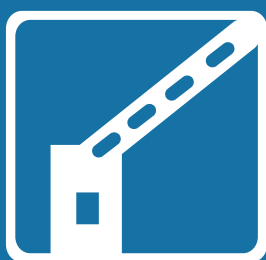

CATALOGUE 2018

COMPANY PROFILE

AUTOZON was established in the year 2015. The headquarter is located in Coimbatore, Tamilnadu,India. We are well-established manufacturers of residential and commercial entrance automation, enriched with high competent technical resources, intelligent systems, own a number of unique core technologies and exchanged cooperation of European design and technologies. Our continuous endeavor to communicating and learning European new technologies is a strategic element in our success.

We specialize in automated industrial doors ,sliding gates operator, swing gates operator,sliding & swing door operator, rolling shutter operator, automatic barriers, motorized curtain.,etc which are widely used in commercial buildings , small,medium,large scale industries ,industrial warehouses , gated communitis and individual villas .Our products boast of many features such as high quality ,stable performance ,convenient installation ,and high safety . We are a high-tech enterprise which integrates R & D, manufacturing, sales and after sales service.

We strictly follow the concept of “quality first, customer foremost “ which is intensely entrenched into the corporate principles. We persistently stick to perfect model, extraordinary quality and innovative cutting-edge technical support “,and expect to provide you with more competitive products , advanced technologies and best service . We sincerely hope to cooperate with all customers. Let's make progress collectively with time and build a vibrant future.

INDEX

| | |
|---|-----------------------|
| <i>1. SLIDING GATE OPERATOR</i> | <i>PAGE 1</i> |
| <i>2. SWING GATE OPERATOR</i> | <i>PAGE 3</i> |
| <i>3. SLIDING DOOR OPERATOR</i> | <i>PAGE 7</i> |
| <i>4. SWING DOOR OPERATOR</i> | <i>PAGE 9</i> |
| <i>5. BOOM BARRIER</i> | <i>PAGE 10</i> |
| <i>6. CURTAIN MOTOR</i> | <i>PAGE 12</i> |
| <i>7. ROLLING SHUTTER OPERATOR</i> | <i>PAGE 13</i> |
| <i>8. ACCESSORIES</i> | <i>PAGE 15</i> |



Product Description

- Appearance of our operator is based on the most advanced industrial design, using latest technology.
- Stylish, elegant and high grade.
- The base is made of non-corrosive high strength aluminium, making it suitable for outdoor use.
- Small size, high power, easy installation and safe operation.
- Patent products with innovative LED indicators and alarm functions.
- Over heat protection function.
- Inbuilt clutch for manual release.

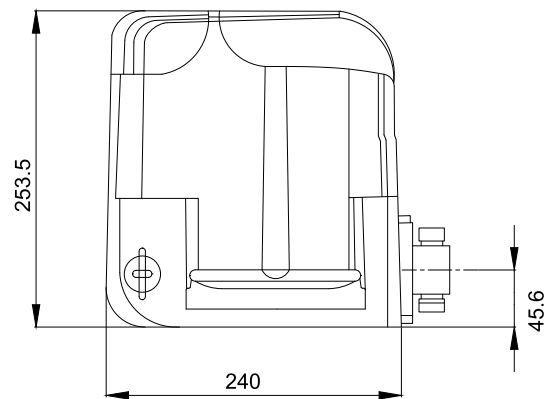

Photocells



Key Switch

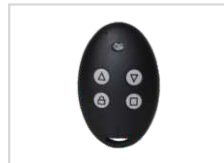

Transmitter



Flash Lamp

Technical Parameters

| Model | AZ 685 | AZ 668 | AZ 678 |
|-----------------------|---------------|---------------|---------------|
| Input Power | AC 220V~240V | | |
| Max. Gate Weight | 500KG | 800KG | 1200KG |
| Max. Torque | 18Nm | 22Nm | 35Nm |
| Rated Power | 370W | 450W | 550W |
| Noise | 56dB | 56dB | 56dB |
| Working Speed (m/min) | 12 | 12 | 12 |
| Temperature range | -20°C ~ +55°C | -20°C ~ +55°C | -20°C ~ +55°C |
| Protection Class | IP 44 | IP 44 | IP 44 |



Product Description

- Appearance of our operator is based on the most advanced industrial design, using latest technology.
- Unique control board with travelling study mode, open and close limits are accurate.
- Motor running strength can be adjusted.
- Over heat protection function.
- Inbuilt clutch for manual release.

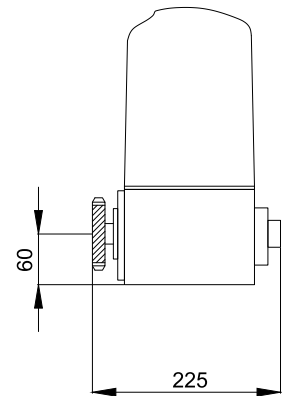
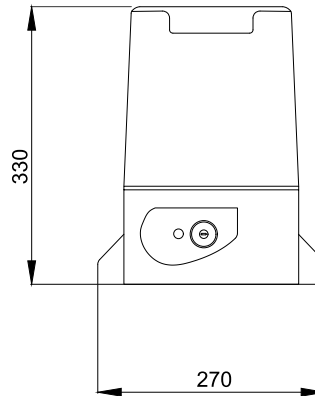

Photocells



Key Switch



Transmitter



Flash Lamp

Technical Parameters

| Model | AZ 200 | AZ 201 |
|-----------------------|---------------|--------|
| Input Power | AC 220V~240V | |
| Max. Gate Weight | 2000KG | 3000KG |
| Max. Torque | 50Nm | 65Nm |
| Rated Power | 750W | 750W |
| Noise | 56dB | |
| Working Speed (m/min) | 12 | |
| Temperature | -20°C ~ +55°C | |
| Protection Class | IP 44 | |



Product Description

- Easier to drive the gate: The motor is mounted on the far end from the hinge point.
- Special sliding groove: This enables the tolerance to the unevenness of road surface up to 70mm, maximum tolerance up to 300mm.
- Unlimited opening angle: As far as the opener is concerned, the opening angle can be greater than 180°.
- Automatic locking : This combines both closing and locking actions.
- Manual release option with customized key.
- Non-corrosive stainless steel base plate.
- This DC 24 volt operator can be connected with domestic UPS.

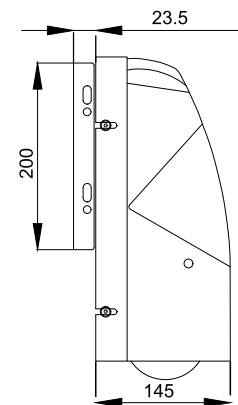
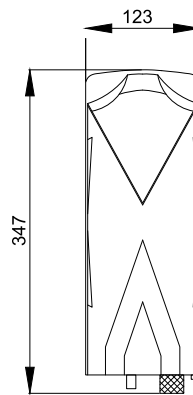

Control Panel



Photocells



Key Switch



Transmitter



Flash Lamp

Technical Parameters

| | |
|------------------------|---------------|
| Model | AZ 850 |
| Input Power | AC 220V~240V |
| Single Leaf Max.Width | 6M |
| Single Leaf Max.Weight | 600 Kg |
| RPM | 2800 RPM |
| Speed | 10-15 m/Min |
| Motor Power | 120W |
| Motor Voltage | DC24V |
| Temperature range | -20°C ~ +55°C |
| Lift Drop | 0-70 mm |
| Protection Class | IP 54 |



Product Description

- Easier to drive the gate: The motor is mounted on the far end from the hinge point.
- Special sliding groove: This enables the tolerance to the unevenness of road surface up to 70mm, maximum tolerance up to 300mm.
- Unlimited opening angle: As far as the opener is concerned, the opening angle can be greater than 180°.
- Automatic locking unit: Additional lock not required, when locked it cannot be pushed or lifted up.
- This DC 24 volt operator can be connected with domestic UPS.

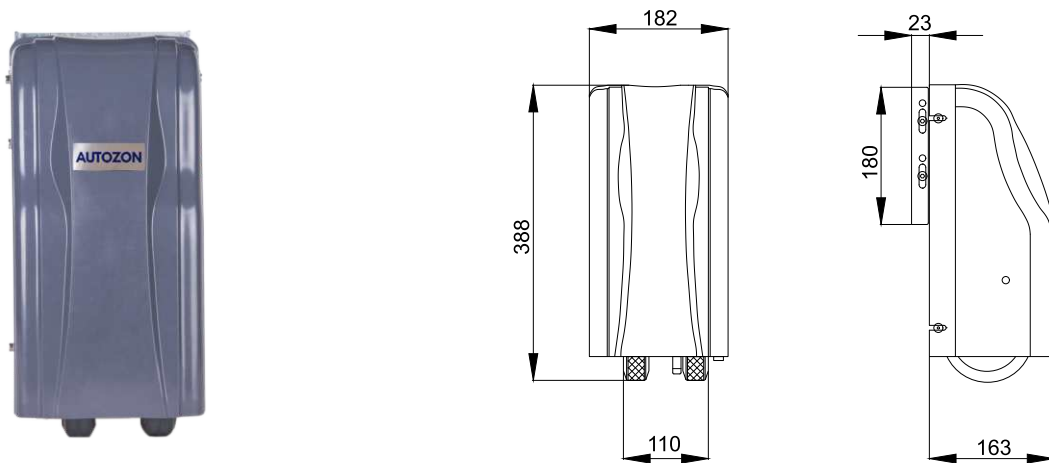

Control Panel



Photocells



Key Switch



Transmitter



Flash Lamp

Technical Parameters

| | |
|-------------------|----------------|
| Model | AZ 998 |
| Input Power | AC 220V~240V |
| Max Weight | 1000 Kg |
| RPM | 2800RPM |
| Speed | 10~15m/min |
| Motor Power | 100W x 2 |
| Motor Voltage | DC24V |
| Temperature range | -20°C ~ + 55°C |
| Lift Drop | 0~70mm |
| Protection Class | IP 54 |



Product Description

- Inbuilt patented mechanical lock, to achieve auto close lock.
- Aluminium alloy body with durable and elegant design.
- Advanced gear box design, silent and stable operations. In one key remote you can control door operations.
- Automatic reverse or stop when touching obstructions.
- Automatic closing time and single door function can be set manually.
- Infrared beam protection and alarm lamp indicators to indicate open and close functions.

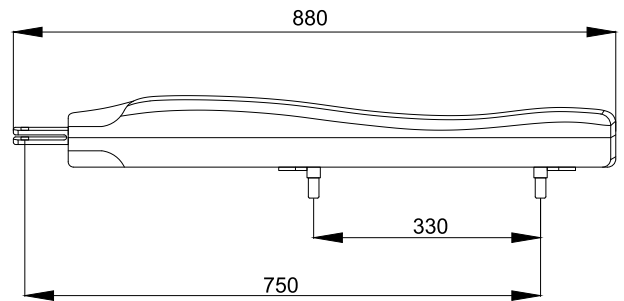

Control Panel



Photocells



Key Switch



Transmitter



Flash Lamp

Technical Parameters

| | |
|---------------------|----------------|
| Model | AZK 28 |
| Max. Gate Width(m) | 2.5 |
| Power Supply (V/HZ) | AC 220V-240V |
| Max. Gate Weight | 300 kg |
| RPM | 2200R/min |
| Motor Power | 120W |
| Motor Voltage | 24VDC |
| Temperature Range | -45°C ~ + 65°C |
| Protection Class | IP 54 |



Product Description

- Inbuilt patented mechanical lock, to achieve auto close lock.
- Aluminium alloy body with durable and elegant design.
- Advanced gear box design, silent and stable operations. In one key remote you can control door operations.
- Automatic reverse or stop when touching obstructions.
- Automatic closing time and single door function can be set manually..
- Infrared beam protection and alarm lamp indicators to indicate open and close functions.

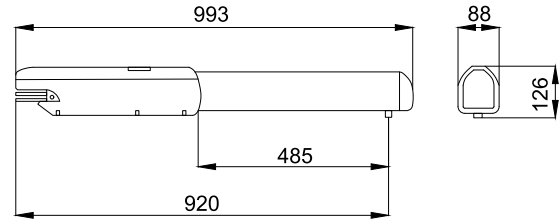

Control Panel



Photocells



Key Switch



Transmitter



Flash Lamp

Technical Parameters

| | |
|-------------------------|----------------|
| Model No. | AZK 23 |
| Input Power | AC 220V~240V |
| Max.width of gate (m) | 5M |
| Max.weight of gate (kg) | 600 |
| Motor Power | 250W |
| RPM | 1400R/min |
| Temperature range (°C) | -45°C ~ + 65°C |
| Protection Class | IP 44 |



Product Description

- Advanced operating system: Sleek DC brushless motor is highly efficient for gentle opening and closing, silent and quick operations and smooth braking system.
- Program designed using the latest technology saves energy and environmental protection.
- Unique manual operation: During power cut, the operation can be easily achieved manually.
- Reliable for silent operation and longer life with new drive, high quality, gear box, helical gears, wheels and high wear structural design.

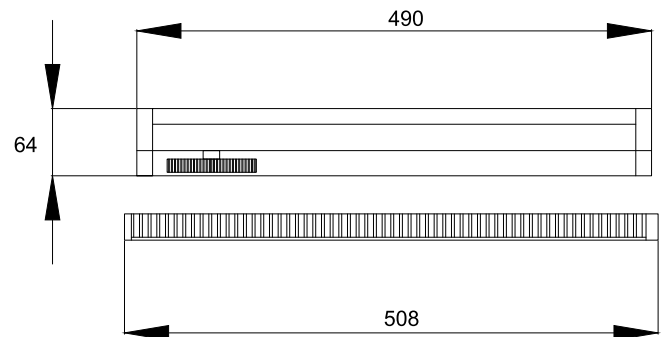

Hand Sensor Switch



Wireless hand press



Microwave sensor



Transmitter & Receiver



Foot touch sensor

Technical Parameters

| | |
|---------------------|-----------------------------------|
| Leaf weight | 80kg |
| Width of door | 950mm |
| Controller | High-performance micro-controller |
| Motor Voltage | DC 24 |
| Opening speed | 400mm/ S (adjustable) |
| Closing speed | 300mm/ S (adjustable) |
| Door hold open time | 0.5 ~ 10s (adjustable) |
| Supply Voltage | AC 220V-240V |
| Temperature | -20 ~ 50°C |
| Motor Power | 45W |



Product Description

- Program designed using the latest technology saves energy and environmental protection.
- Unique manual operation: During power cut, the operation can be easily achieved manually.
- LED Display : Patented with stable and secured operations, IR beam automatically identify obstacles and quickly opens to avoid damage to humans and materials.
- Convenient life : DC brushless motor is highly efficient for gentle opening and closing, more silent and quick operations with smooth braking system.

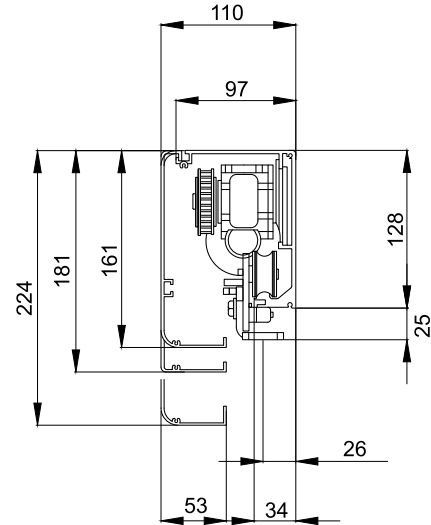

Hand Sensor Switch



Wireless hand press



Microwave sensor



Transmitter & Receiver



Foot touch sensor

Technical Parameters

| | Single Door | Double Doors |
|---------------------|-----------------------------------|-----------------------------------|
| Horizontal pull | Single Door | Double Doors |
| Leaf weight | 100 kg | 80*2kg |
| Width of door | 700~1300mm | 600~1250mm |
| Controller | High-performance micro-controller | High-performance micro-controller |
| Motor Voltage | DC 24V | DC 24V |
| Opening speed | 400mm/ S (adjustable) | 400mm/ S (adjustable) |
| Closing speed | 300mm/ S (adjustable) | 300mm/ S (adjustable) |
| Door hold open time | 0.5 ~ 10s (adjustable) | 0.5 ~ 10s (adjustable) |
| Supply Voltage | AC 220V-240V 50/60HZ | AC 220V-240V 50/60HZ |
| Temperature | -20 ~ 50°C | -20 ~ 50°C |
| Motor Power | 45W | 45W |



Product Description

- Door weight: maximum of 100kgs, opening and closing speed adjustable 3-10s
- Anti-collision function: on opening and closing operation, automatically bounce obstacle and quickly opens to avoid damage to the humans and materials.
- Unlimited opening angle: As far as the opener is concerned, the opening angle can be greater than 180°.

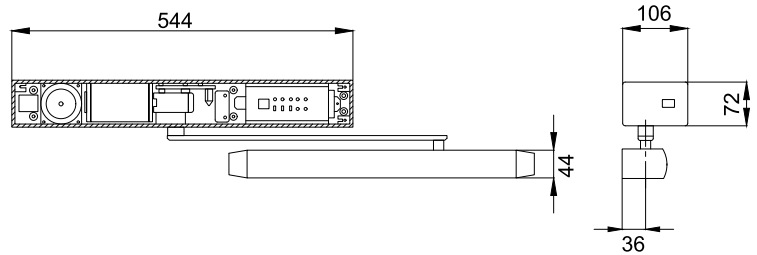

Hand Sensor Switch

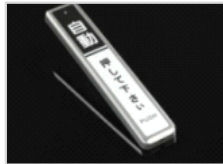

Wireless hand press



Microwave sensor



Transmitter & Receiver



Foot touch sensor

Technical Parameters

| | |
|---------------------|-------------------|
| Model | AZ 02 |
| Weight | 7kg |
| Max.leaf weight | 200kg |
| Open range | 70° ~115° |
| Closing speed | 10 ~43cm/s |
| Door hold open time | 0.5~10 s |
| Main Power | 220V-240V |
| Maximum motor power | 55W |
| Wait Power | 14W |
| Fuse | Minimum 3.5A Slow |



Product Description

- Boom barrier available up to 6 meters in arm length.
- The motor is under over-heat protection so that intensive use never causes a burn-out
- Arm can be manually raised incase of power failure.
- Articulated arms are available for low ceilings
- Can be controlled by radio transmitter, card reader, push button, vehicle induction loop detector
- Extremely sensitive limit switch adopted to guarantee accurate motion of the arm

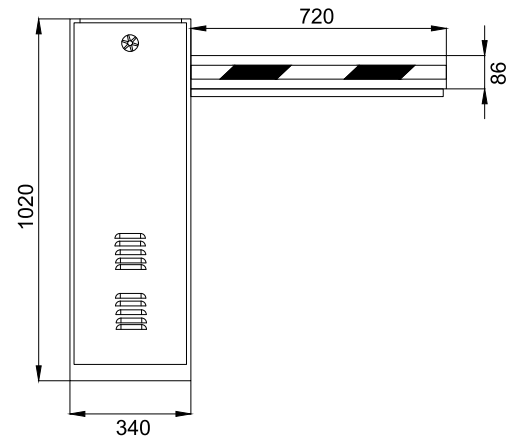
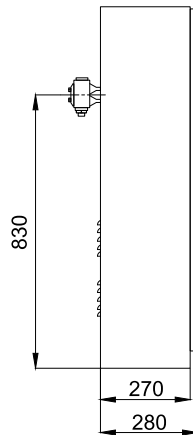

Push Button



Photocell



V- Holder



Transmitter



Flash Lamp

Technical Parameters

| | | |
|-----------------------------------|--------------|------|
| Maximum straight boom length | 1.5s type | 3m |
| | 3s type | 4.5m |
| | 6s type | 6m |
| Length | 1.5s/3s/6s | |
| Input Power | 220V-240V | |
| Frequency | 60HZ/50HZ | |
| Motor power consumption | 100W | |
| Working temperature | -20°to 55°C | |
| Housing dimension | 340*280*1030 | |
| Weight not including barrier boom | 55kgs | |
| Protection Class | IP 44 | |



Product Description

- Boom barrier available up to 6 meters in arm length.
- The motor is under over-heat protection so that intensive use never causes a burn-out
- Arm can be manually raised in case of power failure.
- Articulated arms are available for low ceilings
- Can be controlled by radio transmitter, card reader, push button, vehicle induction loop detector
- Extremely sensitive limit switch adopted to guarantee accurate motion of the arm

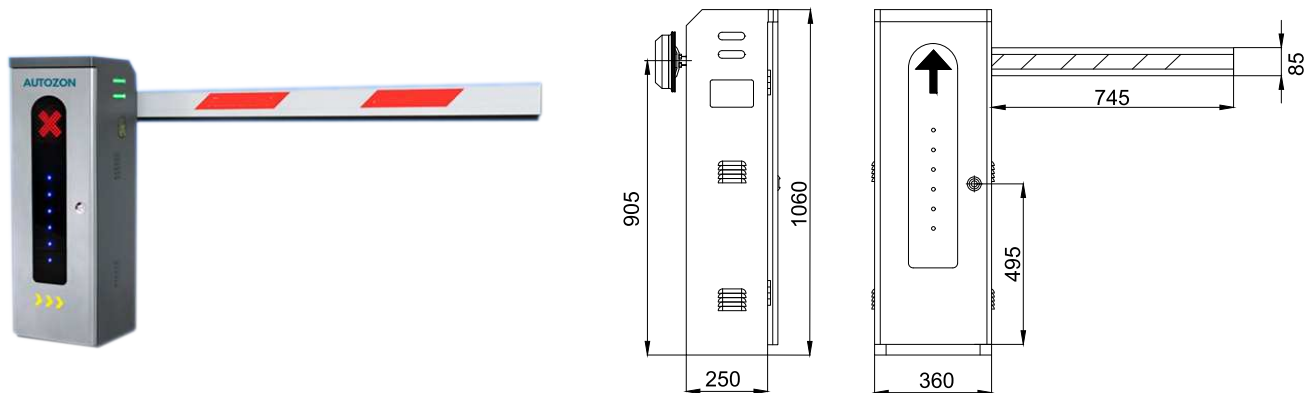

Push Button



Photocell



V- Holder



Transmitter



Flash Lamp

Technical Parameters

| | | |
|-----------------------------------|--------------|------|
| Maximum straight boom length | 1.5s type | 3m |
| | 3s type | 4.5m |
| | 6s type | 6m |
| Length | 1.5s/3s/6s | |
| Input Power | 220V-240V | |
| Frequency | 50HZ | |
| Motor power consumption | 60W | |
| Working temperature | -20°to 55°C | |
| Housing dimension | 355*280*1050 | |
| Weight not including barrier boom | 50kgs | |
| Protection Class | IP 44 | |



CURTAIN MOTOR

Product Description

- Intelligent curtain motor, easy to handle with variable length.
- Efficient alignment of tracks, based on site requirement.
- The tracks can be transferred and assembled with 90° degree angle.
- Easy to transport, easy to carry upstairs.
- DIY Concept, Connect the track yourself at home.

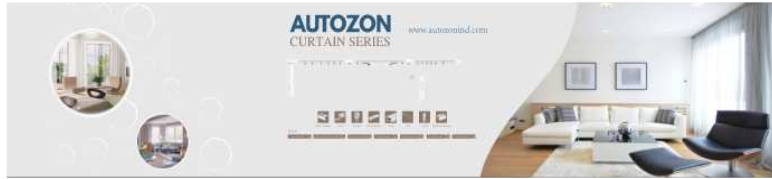

Transmitter AZ201



Transmitter AZ 206



Transmitter AZ 101



Transmitter AZ 102



90 Degree Angle

Technical Parameters

| Rated Torque | Nominal Voltage | Nominal Consumption | Running Noise | Max Load | Radio Distance | IP |
|--------------|-----------------|---------------------|---------------|----------|----------------|-------|
| 1 NM | 230 V | 60 W | 35 dB | 50 KG | >50 M | IP 20 |

| Total length | Length of track (mm) | Track connector (mm) | Length of adjustable track (mm) | | | | | Suitable Size |
|--------------|----------------------|----------------------|---------------------------------|-----|-----|----------------------|-----|-----------------|
| | | | Length of track (mm) | | | Track connector (mm) | | |
| | | | 500 | 200 | 100 | 200 | 100 | |
| 3.2 m | 2 | 2 | 1 | 2 | 1 | 1 | 1 | 2.16 m - 3.16 m |
| 5.2 m | 4 | 4 | 1 | 2 | 1 | 1 | 1 | 4.16 m - 5.16 m |



ROLLING SHUTTER MOTOR

Product Description

- Compact design, attractive appearance, safe and reliable performance.
- It has the advantages of light weight, low noise, convenient to install.
- Available in various specifications as per the client requirement.
- Manual operation in case of power failure.



Receiver



Phase Changer



Key Box



Transmitter

Technical Parameters

AC Series

| MODEL | POWER SOURCE | Type | RATED POWER (w) | LIFTING POWER (kg.f) | Rated Load | | Standard Drum Diameter (inch) | Continued Working Time(min) | MAX HEIGHT(m) |
|------------|--------------|--------|-----------------|----------------------|---------------|---------------|-------------------------------|-----------------------------|---------------|
| | | | | | output torque | output torque | | | |
| AZ-400-1P | 240V | Copper | 250 | 400 | 168 | 4.6 | 4 | 5 | 6 |
| AZ-600-1P | | Copper | 370 | 600 | 412 | 4.6 | 5 | 5 | 6 |
| AZ-800-1P | | Copper | 550 | 800 | 647 | 4.5 | 6 | 5 | 9 |
| AZ-1000-1P | | Copper | 400 | 1000 | 810 | 4.4 | 6 | 5 | 9 |
| AZ-1000-3P | 380V | Copper | 400 | 1000 | 810 | 4.4 | 6 | 5.2 | 9 |
| AZ-1500-3P | | Copper | 800 | 1500 | 1617 | 3.8 | 8 | 5.2 | 9 |



Product Description

- Can work with 200–260 mm springs together.
- Electromagnet brake ensures safety. It holds the shutter from coming down in case of power failure.
- The brake can be manually released in case of emergency or power failure to open or close.
- Easy installation, no need to use adaptor.
- Mechanical limit.
- Low noise.

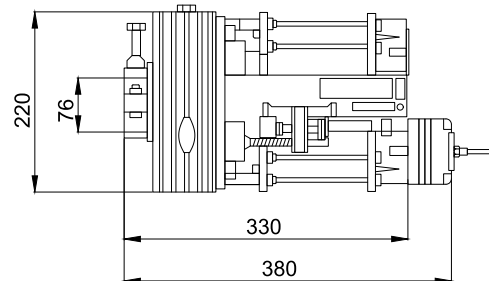
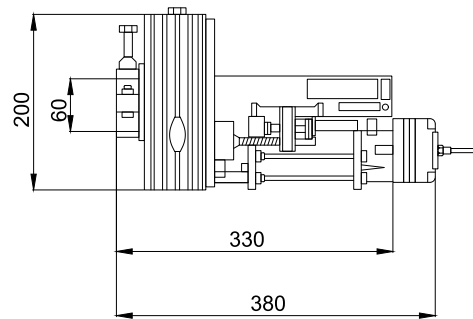

Control Panel



Key Selector



Remote

Technical Parameters

| | Model | Torque | Rotating | Running Time Time | Rated Voltage | Rated Frequency | Rated Power | Lifting Capacity | Tube dia. | Pulley | Operator Weight |
|------|---------------|--------|----------|-------------------|---------------|-----------------|-------------|------------------|-----------|---------|-----------------|
| 220V | SF200/60-180H | 180 | 10 | >4 | 230 | 50 | 580 W | 200 KG | 60 | 200-220 | 10.5 kg |
| 240V | SF240/76-360H | 360 | 8 | >4 | 230 | 50 | 880 W | 300 KG | 76 | 240-260 | 14.6 kg |



ACCESSORIES

Sliding & Swing Gate Operator Accessories



Control Panel



Photocells



Key Switch



Transmitter



Flash Lamp

Sliding & Swing Door Operator Accessories



Hand Sensor Switch

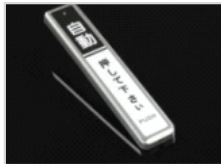

Wireless hand press



Microwave sensor



Transmitter & Receiver



Foot touch sensor

Boom Barrier Accessories



Push Button



Photocell



V- Holder



Transmitter



Flash Lamp

Curtain Motor Accessories



Transmitter AZ201



Transmitter AZ 206



Transmitter AZ 101



Transmitter AZ 102



90 Degree Angle



ACCESSORIES

Rolling Shutter Accessories



Receiver



Phase Changer for 3 phase



Key Box



Transmitter

Centre Motor Accessories



Control Panel



Key Selector



Remote

General Accessories



GSM Dialler



Key Fab



External Receiver



Swing gate ground lock



Battery Backup



AUTOZON™

✉ info@autozonind.com

🌐 www.autozonind.com

